

Orbis Systems India

Automotive Sector Project
References



WE CALL IT KNOWLEDGE

- ✓ More than 10 years of experience in automated testing in India
- ✓ India Delivery references since 2005:
 - More than 500 quality assurance & functional device testers
 - More than 500 flashing test systems delivered
 - More than 500 fixtures & adaptors
 - More than 100 thousand km of cable assemblies

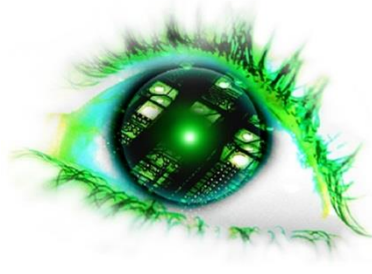

Complete Assembly Line Support

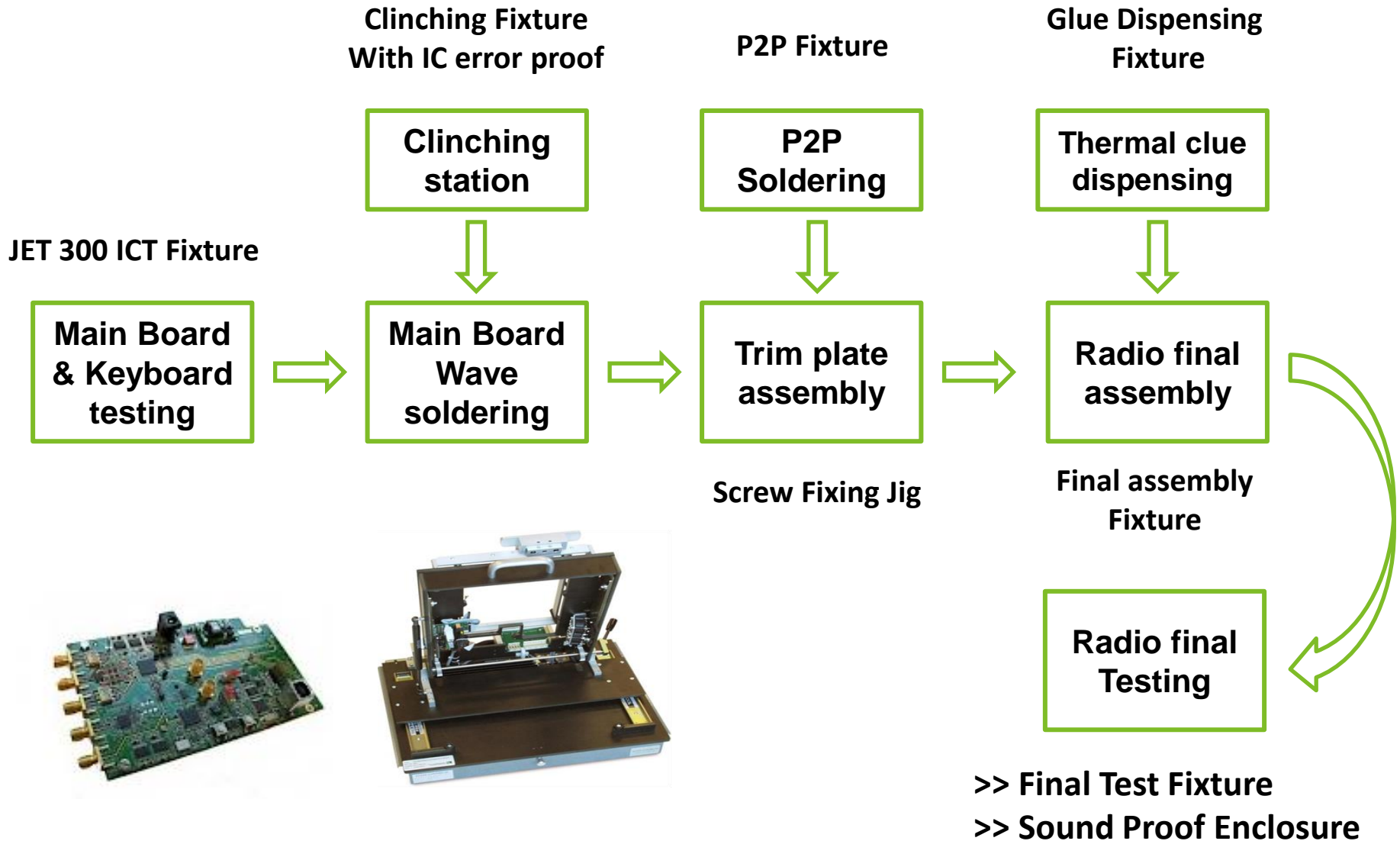

✓ Mass Interconnect Solution

- Inspection of wrong assemblies
- Custom designed gauges
- Precise mechanics for testing reliability



✓ RF Test Set

- Functional / Performance test for radiation and susceptibility
- Broadband TEM Cell up to 3 GHz
- High shielding: >80dB at 2GHz and 70dB at 3GHz

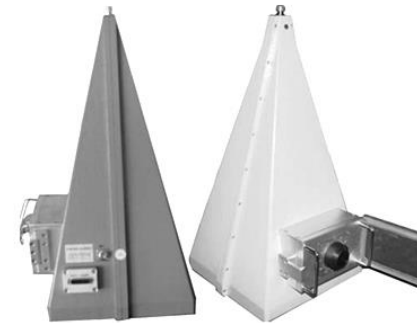

✓ Features:

- ICT Fixture for JET-300 machine
- Fixture to test the SMD components for dry soldering and faulty components
- 512 Test Points
- Counter for measuring test cycles
- Cost effective design

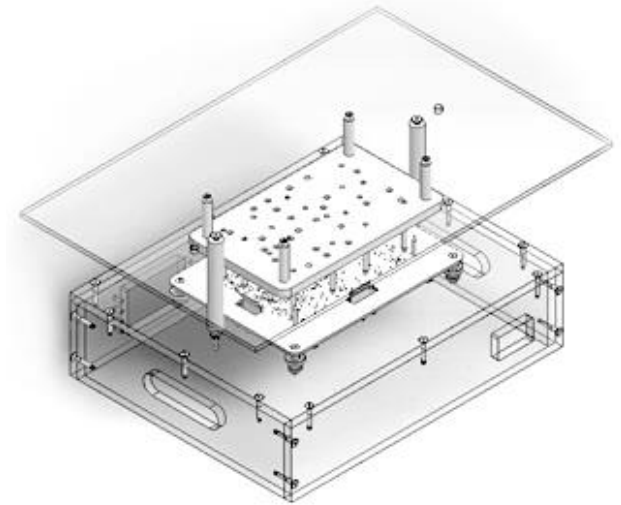

- ✓ Pneumatically operated fixture for heat sink bracket clinching
 - In-built IC error proof checking logic
 - Clinching is operated only if the correct IC's are placed
 - Wrong IC's are identified with LED indications

- ✓ Applications & Benefits
 - Placement of correct IC's is checked before Clinching
 - Reduces rework time

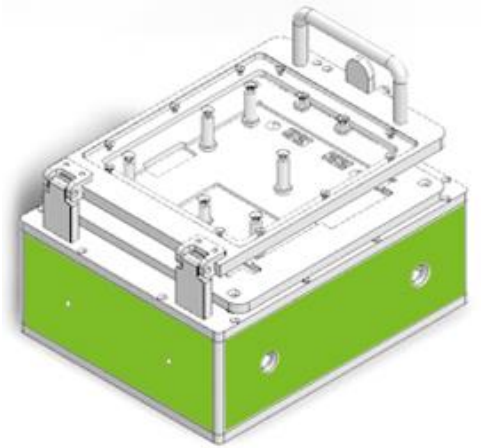

✓ Features

- Concepts supports test automation
- Upgrades to support assembly verification

✓ Other

- Radio System: FT - Base & Mother fixture
- Pallets for Wave Soldering



✓ Features

- Assembly automation jigs & fixtures
- Manual, Semi-Automatic & Fully Automatic types
- Pneumatic, Electro magnetic
- Assembly verification
- Conveyors – Shuttle, Full-line



✓ ATE / Testers:

- Fuse Box Inspection
- Instrument Cluster Inspection
- RF tester: Remote Keyless Entry
- Audio tester: AM/FM, Bluetooth's Audio Functions
- Audio – Main board: ICT Tester/ Fixture
- Immobilizer tester / fixture
- EOL - Functional / Visual Inspection tester



✓ Assembly automation:

- Heat Control Switch (Seats) – Assembly Stage 1 & 2
- Radio housing / PCB Assembly

✓ Other

- Customized Connector with Housing for Cable Harness